

STRUCTURAL STRENGTHENING WITH A NEW SYSTEM OF PRESTRESSED CFRP STRIPS

Uwe NEUBAUER Wiebke VOM BERG Peter ONKEN

Bow consultants ltd., Breite Straße 15, D-38100 Braunschweig, Germany

Keywords: anchorage, anchor plate, CFRP, externally bonded reinforcement, passive clamping force, prestress, serviceability, strengthening.

1 INTRODUCTION

For many years, CFRP strips as externally bonded reinforcement (EBR) for the strengthening of concrete structures have been applied without prestress. For convenience and quick installation, they usually come without special end anchorages. This has a major drawback: Only about 50% of the tensile strength of the CFRP material can be exploited because debonding becomes critical. This has long been a big annoyance because it is inefficient and even impedes some applications.

Anchorage devices prevent debonding at the strip ends. Bond failure though can also occur anywhere between the anchorages at high bond stresses due to concentrated loads, rebar yield etc. [1, 2]. Consequently, debonding has to be prevented by economically undesirable limitations of the CFRP strain.

Lately, systems with prestressed CFRP strips appear on the market. Besides strengthening, they can also improve the serviceability more effectively than conventional strips. Furthermore, the CFRP material can be exploited much more economically. This is partially due to the end anchorages as such, preventing debonding at the strip ends, thus allowing higher forces. However, the prestressing force itself also contributes to the increased effectiveness, as it does not cause bond stresses.

In this paper the term “strips” will be consistently used for the product type, described in 3.1.

The following indices will be used:

f: CFRP strips (fibre), p: prestress, s: steel reinforcement, A: anchorage, d: design,

S: stressing forces, R: resistance of structural members

2 GENERAL COMPARISON OF PRESTRESSED AND UNSTRESSED CFRP-STRIPS

The principle of EBR is well known. For the essential bond problems, it is referred to [1, 2]. Since the prestressing force cannot be anchored by adhesive bond alone, mechanical anchorages are necessary. In addition to conventional EBR, prestressed strips introduce axial compression and a moment, counteracting the external loads. As the prestressing force is constant between the anchorages, only loads, applied after hardening of the adhesive cause bond stresses. The CFRP stress then consists of the prestress and the stress due to subsequently applied loads. Figure 1 shows the strip force in unstressed and prestressed strips for the same external load. The strip force $F_{f,A}$ at the anchorage A consists of the prestress component $F_{f,P}$ and the component due to subsequently applied loads $F_{f,Load,A}$.

For these reasons the tensile capacity can be exploited more efficiently with a higher total strain than in unstressed strips. Consequently, if the tensile strength is not critical, less material is needed for a certain tensile force. Alternatively, serviceability is improved more effectively with the same amount of CFRP, if prestressed. In Figure 2, the CFRP efficiency, expressed as CFRP stress at point “max” dependent on the prestress, both normalized to the tensile strength is shown. A prestress of over $0.3 \times$ tensile strength allows to exploit the tensile capacity by 80%, compared to only 50% in conventional strips with anchorages and often even lower values for conventional strips without anchorages. These approximate figures apply to a newly developed system, where the need for heavy invasion into the structure such as chiselling or core drilling, in order to install the anchors has largely been eliminated.

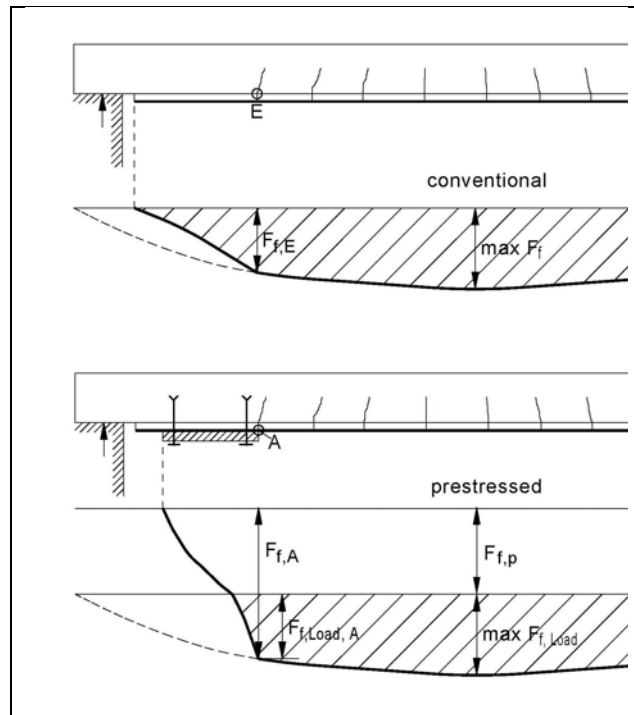

Fig. 1 Comparison of forces and end anchorage in prestressed and unstressed CFRP strips.

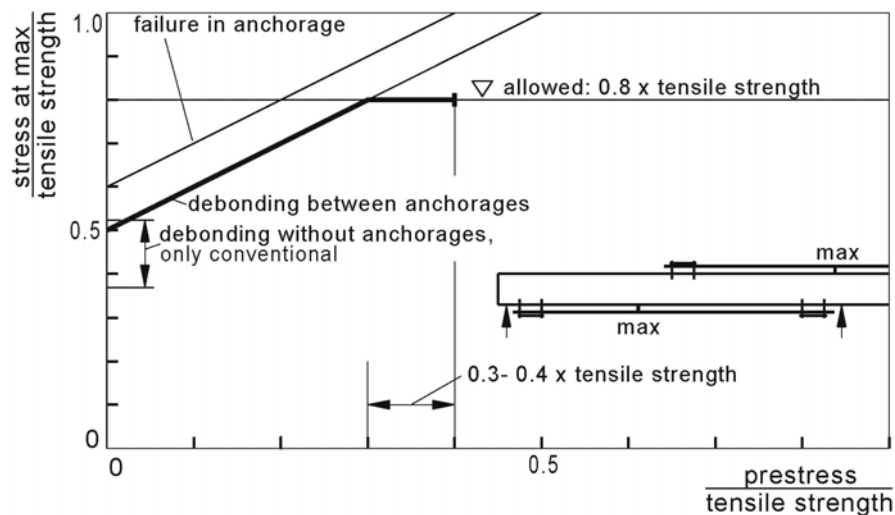

Fig. 2 CFRP efficiency: stress at "max" over the prestress, both normalized to the tensile strength.

3 THE STRENGTHENING SYSTEM WITH PRESTRESSED CFRP STRIPS

3.1 Components

The system uses commercially available 1.2 mm thick unidirectional CFRP strips, 50 – 100 mm wide, $E_f = 160.000$ MPa, tensile strength 2.500 MPa and a two-component epoxy adhesive. Uneven concrete surface is levelled out with epoxy repair mortar. The primer-coated anchor plates, 220 x 400 x 12 (mm)

are made of steel Fe 360, yield strength 235 MPa. They are fastened to the concrete by eight galvanized self-undercutting anchors for through fastening, grade 8.8, effective anchorage depth 100 mm, drill diameter 20 mm. They are suitable for cracked and uncracked concrete and can be upgraded for dynamic loads. In Figure 3 the complete system during installation including jack, clamps etc. is depicted.

3.2 Installation and prestressing

After the installation of eight self-undercutting anchors per anchor plate, the CFRP strip is glued to the concrete. Then the 12 mm thick steel anchor plates are placed over the CFRP strip and screwed to the anchor bolts. Spacer screws provide a 6 mm glue-filled gap between anchor plate and concrete, allowing the CFRP strip to slide underneath the anchor plate while being prestressed. The ends of the strips are attached to temporary clamps beyond the anchor plates. At the dead-end anchorage, the clamp rests against the anchor plate. At the prestressing anchorage a hydraulic jack is bolted to the anchor plate and pushes the temporary clamp outwards, stressing the CFRP strip. As the adhesive is still soft, the prestressing force is completely carried into the concrete via dowel action between the anchor bolts and the anchor plate. In Figure 4 the prestressing jack and in Figure 5 the dead-end anchorage is shown.

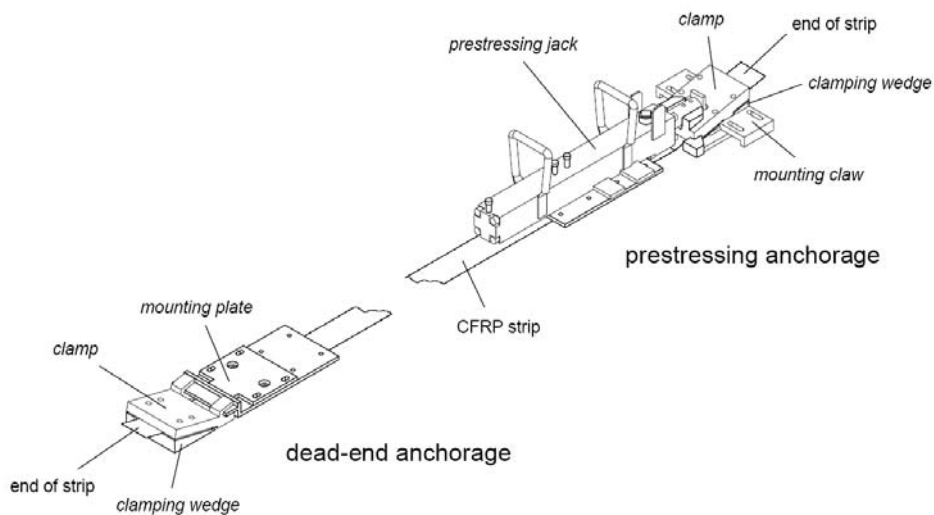

Fig. 3 System with prestressed CFRP-strips during installation.



Fig. 4 Prestressing jack with temporary clamp, arrow indicates direction of prestressing.



Fig. 5 Dead-end anchorage with temporary clamp.

In Figure 6 the system during prestressing together with the dowel forces is shown. The force of the CFRP strip is equal to the jacking force and is constant between the temporary clamps. The prestress is controlled via the displacement Δl of a control marker on the strip with regard to another control marker on the concrete. It is usually sufficient to use a conventional ruler to measure Δl . One can obtain the necessary displacement by multiplying the desired prestrain ε_p with a control length l_c between the temporary dead-end clamp and the control marker. This l_c should be as long as possible for good accuracy. Before the markers are attached, a small preload should straighten the CFRP strip.

After the target displacement is attained, the prestressing jack is locked in the end position. Inevitably, there will occur some prestrain loss due to leaks in the hydraulic system. This loss must be determined in advance for each individual jack and must be allowed for when stipulating the target displacement.

The jack remains in this position until the adhesive has hardened. When the jack is released, the relaxing strip end slips back into the anchorage a bit. The resulting relative displacements between CFRP and concrete induce bond stresses with their maximum near the outer end of the anchorage. The bond stresses due to subsequently applied external loads though have their maximum at the inner end of the anchorage, consequently both maxima do not coincide. This is advantageous compared older anchorage types, where the prestress is applied after the adhesive has hardened. In that case, the bond stresses due to prestress and external loads both reach their maximum near the inside edge of the anchorage.

There will be considerable redistribution of the prestressing force in the anchorage from dowel action to the comparatively rigid adhesive bond, resulting from minor creep displacements. Eventually, the total tensile force of the CFRP strip at the anchorage (point A) will be anchored by a combination of dowel action and adhesive bond, even though their respective shares cannot exactly be quantified. The arrows in Figure 7 indicate this.

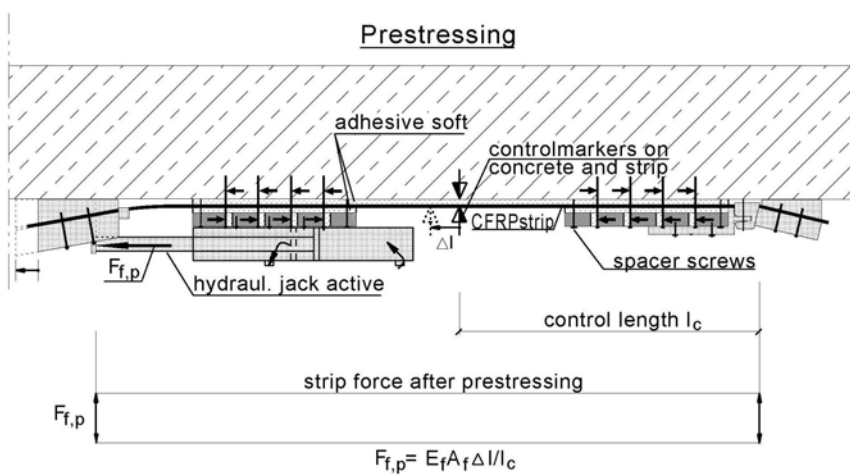

Fig. 6 Installed system during prestressing.

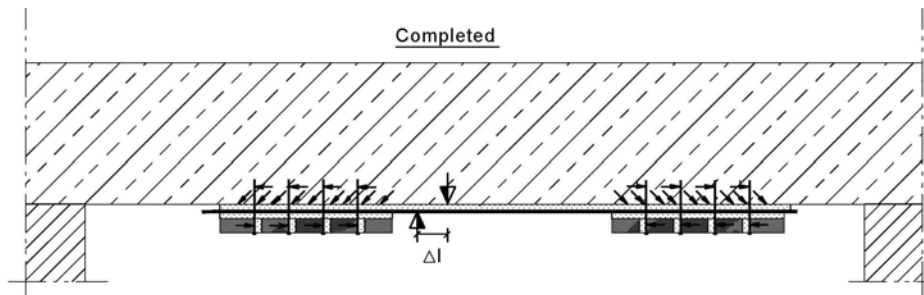

Fig. 7 Completed system, force is anchored by dowel action and adhesive bond (arrows).

3.3 Mechanical principle of the anchorage

This new system uses steel anchor plates and low-invasive self-undercutting anchors. Instead of an active clamping force, applied by tensioned bolts, the system works by a combination of dowel action and adhesive bond, improved by a passive clamping force.

In Figure 8, the forces over a segment Δx of the anchor plate are shown. The vertical displacement of commencing bond cracks is impeded by the anchor plate, which is both glued and bolt-anchored to the concrete. The self-undercutting anchors obtain a tensile force N_D , exerting a vertical clamping pressure σ_n on the CFRP strip, which considerably increases the bond strength. Owing to the roughness of the bond crack surface, the magnitude of this "self induced" clamping pressure corresponds to the force of the strip. It does not depend on actively tensioned bolts and will therefore not decrease over time due to relaxation or concrete creep.

The anchor is not susceptible to pull-out failure as the tensile force N_D is an internal force, being in equilibrium with the clamping pressure. As mentioned previously, part of the force is carried by dowel action, depicted as V_D in Figure 8.

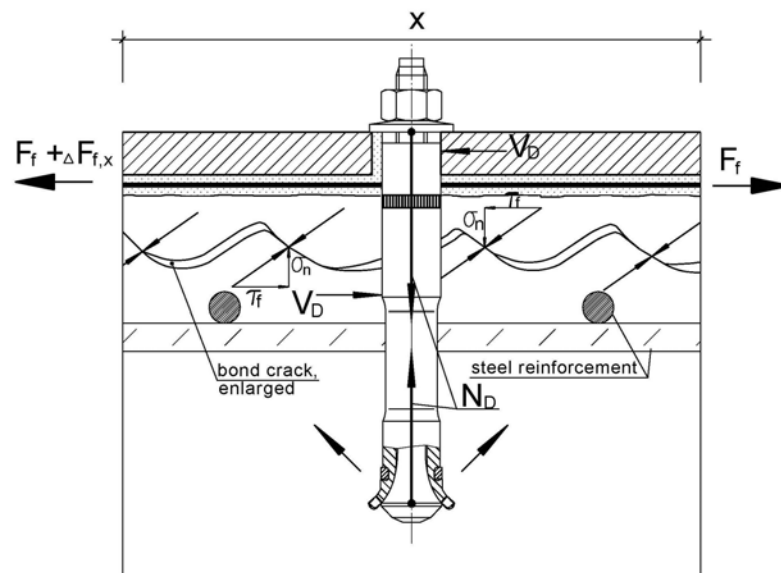

Fig. 8 Mechanism of strip anchorage via adhesive bond τ with self-induced clamping pressure σ_n and dowel action V_D .

Passive clamping pressure has long been proven and used to transfer shear stress across rough interfaces, intersected by reinforcement. Shear cracks in R/C beams and the strengthening with concrete overlays, using shear connectors are common examples [3, 4]. In EBR, steel plate stirrups, embracing the longitudinal strips, effectively inhibit the bond crack propagation and thus considerably increase bond strength. Figure 9 shows this phenomenon in a beam, strengthened with CFRP-strips. The strip strain reached $\varepsilon_{fu} = 12.6 \text{ ‰}$, twice the value, that would have been possible without steel plate stirrups [5]. The same mechanism works in near surface mounted reinforcement, glued into slots [6].

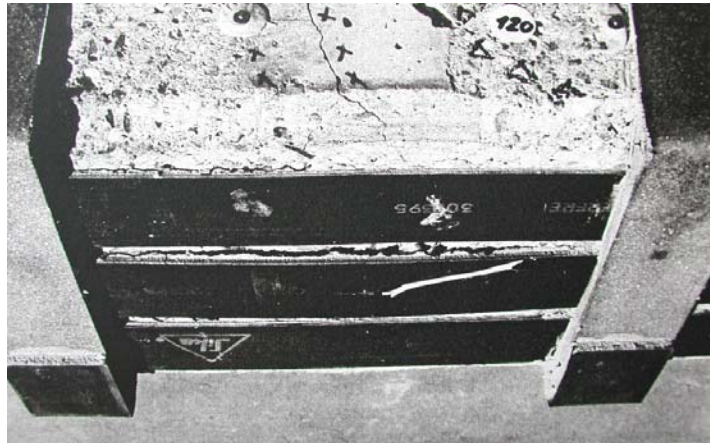

Fig. 9 Bond crack arrest by externally bonded steel plate stirrups [5].

3.4 Test results

The long-term as well as the fatigue behaviour of the anchorages was tested in the Institute for Testing of Building Materials in Braunschweig, Germany. CFRP strips, about 3 m long were mounted to a concrete slab according to the manufacturer's instructions and were prestressed to $\varepsilon_f = 7.25 \text{ ‰}$. The relative displacements between CFRP-strip and concrete and between anchor plate and concrete were measured over a period of six months and were found to be in the order of less than 1/100 mm and consequently negligible. The loss of CFRP stress at the anchorage over the six months period was 2.8% of the initial prestress. It was found, that this loss can entirely be attributed to creep and shrinkage of the concrete slab, confirming that there is no measurable anchorage slip.

The fatigue behaviour was tested in a four-point bending slab, with four anchorages situated in the region of the maximum bending moment and consequently in an area of cracked concrete, as shown in Fig. 10. The anchors were *not* equipped with the dynamic set, described above. The CFRP-strips were prestressed to a strain $\varepsilon_f = 5.9 \text{ ‰}$. A fatigue bending load, resulting in a strain amplitude of $\Delta\varepsilon_f = 1 \text{ ‰}$ was applied. This amplitude must never be exceeded in a structure, in order to prevent fatigue failure of the steel reinforcement.

The anchorages survived four million load cycles without damage. Then the CFRP-strain amplitude was increased to $\Delta\varepsilon_f = 1.5 \text{ ‰}$. Only then the slab failed after 47.000 more load cycles due to fatigue failure of the steel reinforcement. The CFRP-anchorages remained intact over the entire test. The relative displacement between CFRP and concrete at the anchorages did not exceed 1/100 mm.



Fig. 10 Test slab for fatigue testing of the anchorages, anchorages after slab failure still intact.

3.5 Recommendations for design

The allowable prestress is determined by the anchorage capacity. From the tests described and from other available tests [7, 8] as well as from theoretical reasoning, an allowable design value of the total CFRP strain at the anchorage of $\varepsilon_{f,A,d} = 6,50 \text{ ‰}$ was derived. This corresponds to a CFRP stress of $\sigma_{f,A,d} = 1040 \text{ MPa}$ and consists of the prestress and load components, which may vary within the total value according to structural requirements, e.g. $\varepsilon_{f,p,d} = 5,00 \text{ ‰}$ (900 MPa), $\varepsilon_{f,Load,A,d} = 1,50 \text{ ‰}$ (240 MPa). The total maximum strain must be limited to $\varepsilon_{f,max,d} = 12 \text{ ‰}$. As already indicated, in dynamically loaded structures, the steel reinforcement must be checked for fatigue in any case. Because this inevitably leads to allowable steel strain amplitudes of $\Delta\varepsilon_s < 1 \text{ ‰}$, no extra fatigue design of the anchorage is required. Since in the fatigue tests the anchors exhibited excellent behaviour even without dynamic set, there is still some margin for dynamic applications with aggravated safety requirements.

As the adhesive bond in the anchorage is subjected to long term loading, the allowable temperature is restricted to 30°C for long term and to 35°C for short-term temperature.

The effect of the subsequently applied prestress on the structure must be examined. The prestressing force must be actually effective at its allocated place and not go astray in adjacent parts of the structure.

It has been found, that there is some loss of prestress due to leaks in the hydraulic system, when the prestressing jack is locked into the end position. This loss must be determined in advance for each individual jack and must be allowed for when stipulating the target displacement. The same applies for the effects of creep and shrinkage. In older structures, shrinkage will usually be negligible but creep due to the prestressing force may play a role.

4 PRACTICAL APPLICATION: STRENGTHENING OF SLABS AND BEAMS

Instead of light partition walls, rather heavy masonry walls have been built in a newly erected residential- and office building. Some time after completion, this overloading caused excessive deflection of a wide-spanning concrete flat slab. This was due to the initial elastic deflection and the subsequent creep deformation, resulting in severe cracks in the masonry walls on this slab, as shown in Fig. 11.

It was also found that the bending capacities of the slab and the beams were insufficient, strengthening was necessary. Because of their advantages, externally bonded CFRP-strips were envisaged. In this case, the required CFRP-forces were too high to be anchored by adhesive bond alone. This called for special end anchorages, such as the ones of the system, introduced in this article. Furthermore, the possibility, to apply prestress was particularly welcome, for this helps to reduce deflections due to live loads. The effect of the prestressing forces was examined in an FE-model of the

entire structure. This was to ensure that the prestress was effective where the slab was in need of strengthening and did not harm the statically indeterminate structure.



Fig. 11 Underdesign of concrete slab causes excessive slab deflection and wall cracks.

The design of the CFRP for bending and anchorage was conducted with the aid of a design program, specifically developed for structural strengthening by EBR. It is capable to take into account the deformation due to dead loads, present before the CFRP is bonded to the surface [9].

Figure 12 left shows the strains at the time of strengthening, which was done after removal of the masonry walls and before their substitution by light partition walls. Generally, it is recommended to strengthen under lowest possible dead loads in order have the EBR participate in load carrying as much as possible. It can be seen, that the R/C-section itself exhibits very little deformation of the concrete ε_c and the steel reinforcement ε_s . The CFRP-strain due to prestress is $\varepsilon_f = 6\text{‰}$. On the right, strains of the strengthened member under design loads, i.e. dead and live loads are shown. The total CFRP-strain of $\varepsilon_f = 10\text{‰}$ means a much better exploitation of the material than in unstressed strips without anchorages.

In Figure 13, a screenshot of the design of a typical member is shown. The acting ULS-moment $M_{Sdf} = 46.46 \text{ kNm}$ is $\eta = 1.71$ times greater than the resisting ULS-moment $M_{Rd0} = 27.2 \text{ kNm}$ of the unstrengthened member. After bonded CFRP-strips with a cross-sectional area of $A_{f,prov} = 1.07 \text{ cm}^2$ are provided, the resisting ULS-moment of the strengthened member is $M_{Rdf} = 53.2 \text{ kNm} > M_{Sdf} = 46.46 \text{ kNm}$.

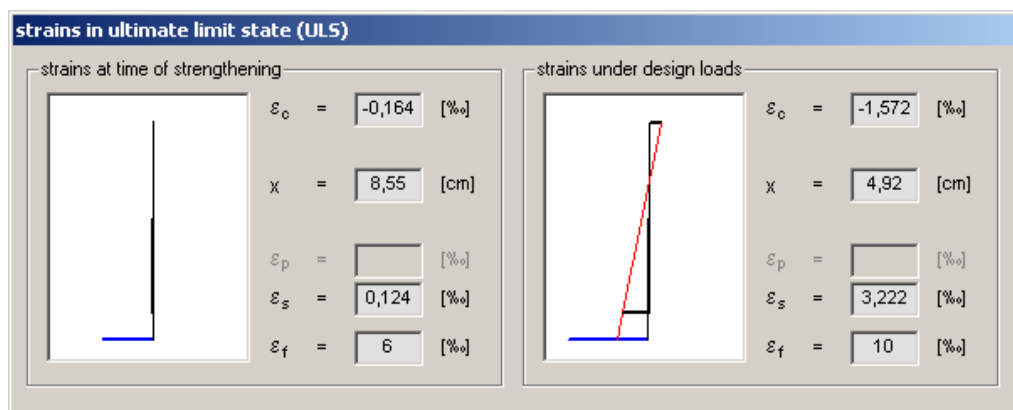

Fig. 12 Strains at the time of strengthening under minimal dead loads and strains of the strengthened member under design loads.

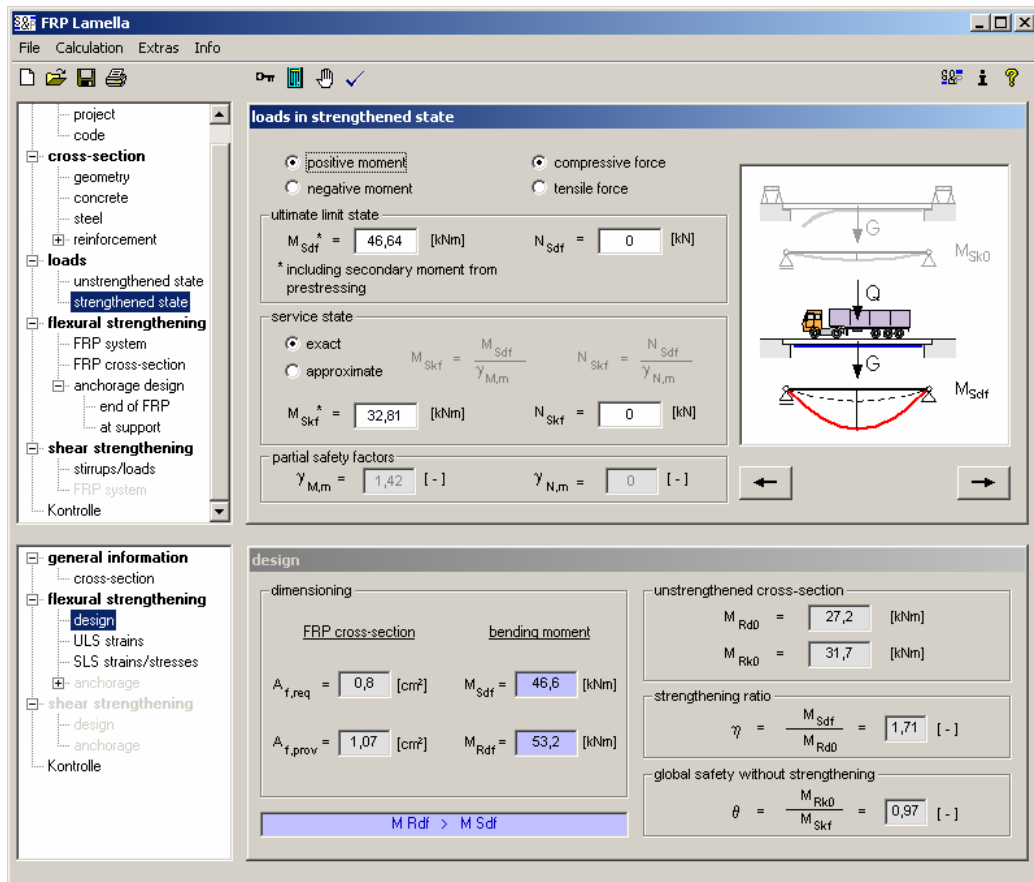

Fig. 13 Typical screenshot of computer aided CFRP-dimensioning, acting forces (S) and resisting forces (R), strengthening ratio η .

In Figure 14 a beam, strengthened with prestressed CFRP-strips and steel plate stirrups, anchored in the compression zone, is shown.



Fig. 14 Beam, strengthened with prestressed CFRP-strips and steel plate stirrups, anchored in the compression zone.

5 SUMMARY

Besides the strengthening effect, prestressed CFRP strips can improve the serviceability of the strengthened member by introducing forces, counteracting the external loads. Since the prestressing force of the CFRP strip cannot be anchored to the concrete by adhesive bond alone, mechanical anchoring devices are necessary. As the prestressing force, applied before the adhesive hardens, does not stress the adhesive bond, the tensile strength of the expensive CFRP can be exploited more economically than in unstressed strips. A new system, using steel anchor plates and low-invasive self-undercutting anchors is introduced. The anchorage works by a combination of dowel action and adhesive bond. The latter is greatly improved by the anchor plate, restraining commencing bond crack openings, thereby inducing a passive clamping force. The paper explains the mechanical principles, especially of the anchorage, describes technical features and presents a practical application. The system is expected to be officially approved in Germany by the end of 2006.

ACKNOWLEDGEMENTS

The support of S&P Clever Reinforcement Company, Brunnen, Switzerland who kindly helped the authors with test reports and demonstration material is gratefully acknowledged. We also wish to thank Prof. Dr. Sc. tech. René Suter of the Ecole d'ingénieurs et d'architectes de Fribourg, Switzerland for allowing us access to his laboratories, patiently answering our questions about the tests he conducted and for giving us insight into his test report.

REFERENCES

- [1] Neubauer, U., Rostásy, F. S: "Debonding mechanism and model for CFRP plates as external reinforcement for concrete members", *International Conference Composites in Construction CCC 2001*, Porto, Portugal, 2001
- [2] Niedermeier, R.: "Zugkraftdeckung bei klebarmierten Bauteilen", Doctoral thesis, Technische Universität München, Germany, 2001
- [3] Randl, N.: "Untersuchungen zur Kraftübertragung zwischen Alt- und Neubeton bei unterschiedlichen Fugenrauigkeiten", Doctoral thesis, Institut für Betonbau der Leopold - Franzens - Universität Innsbruck, Austria, 1997
- [4] Daschner, F.: "Versuche zur notwendigen Schubbewehrung zwischen Betonfertigteilen und Ortbeton", *Heft 372 des Deutschen Ausschusses für Stahlbeton, Verlag Ernst & Sohn, Berlin 1986*
- [5] "Biege- und Schubtragverhalten eines mit geklebten CFK-Lamellen und Stahllaschenbügeln verstärkten Stahlbetonträgers". *Untersuchungsbericht Nr. 8516/8516 -Neu- vom 13. 05. 1996*, Institut für Baustoffe, Massivbau und Brandschutz der TU Braunschweig
- [6] Blaschko, M.: „Zum Tragverhalten von Betonbauteilen mit in Schlitze eingeklebten CFK-Lamellen“, Doctoral thesis, Technische Universität München, Germany, 2000
- [7] Suter, R., Jungo, D.: "Vorgespannte CFK-Lamellen zur Verstärkung von Bauwerken", *Beton- und Stahlbetonbau* 96, Heft 5, 2001.
- [8] Tan, K., Tumilan, K., Nanni, A.: "Evaluation Of CFRP-Systems For The Strengthening Of RC Slabs, *Interim Report*", Center For Infrastructure Engineering Studies, University of Missouri–Rolla, Missouri, USA, 2002.
- [9] Onken, P., vom Berg, W., Matzdorff, D.: "FRP Lamella, design software for flexural and shear strengthening with FRP materials according to Eurocode 2, User manual", *bow ingenieure gmbh*, Braunschweig, Hamburg, Germany, 2006, 99 pages